

## Application Brief M-101

### Introduction

This guide answers the most often-asked questions about encoders in general and Avago Technologies encoders in particular. It is organized into the following sections:

- General Encoding
- Output Waveforms
- Resolution
- Mounting
- Materials
- Reliability
- Electrical
- Miscellaneous

### General Encoding

#### Question 1.

##### What is an encoder?

Answer. An encoder is a sensor of mechanical motion. It translates motion (such as position, velocity, and acceleration) into electrical signals.

#### Question 2. What kinds of encoders are available?

Answer. The three basic types of encoders are contact (also called resistive or potentiometers), magnetic, and optical. Contact encoders use either a wiper which picks off a voltage corresponding to its position, or has a brush or series of brushes which wipe along a codewheel with an alternating conductor/insulator pattern. The pattern of insulator and conductor corresponds to mechanical position. Magnetic encoders sense a magnetic field which changes according to mechanical position. Examples of magnetic encoders include synchros, resolvers, and Hall effect sensors. Optical encoders have a light source which shines through or reflects off a codewheel or codestrip to a photodetector. The photodetector sees a pattern of light and dark which corresponds to the mechanical position.

Encoders generate either analog or digital output signals. An analog encoder may put out a voltage or a series of voltages corresponding to position, velocity, etc. A digital encoder puts out signals which represent a binary 1 or 0 (logic level high or low). The coding of the 1's and 0's determines the position.

#### Question 3.

##### What is the difference between an absolute and an incremental encoder?

Answer. Absolute encoders have a unique value (voltage, binary count) for each mechanical position and thus the position is known “absolutely”. At power up, the position of an absolute encoder is known. Incremental encoders have output signals which repeat over the range of motion and thus each mechanical position is not uniquely defined. The current position sensed is only incremental from the last position sensed. Thus at power up, the position of an incremental encoder is not known since the output signals are not unique to any singular position. Count and direction information can be obtained from both absolute and incremental encoders.

#### Question 4.

##### What is a channel?

Answer. A channel is an electrical output signal from an encoder. Typical high performance incremental encoders have either two or three channels.

#### Question 5. What is quadrature?

Answer. All Avago encoders have channels A and B which output identical repeating square waves as motion occurs. Channel A is offset from channel B by half of a high pulse of the square wave on either channel. Quadrature is the offset relationship between channel A and channel B.

**Question 6. What is meant by 4X decoding?**

Answer. The rising edge to rising edge (called the Cycle) on either channel A or B signifies that one window and bar pair of the codewheel has rotated by the photodetector array. Because A and B are in quadrature, four unique logic states are defined for each window and bar pair that mechanically passes. When these four unique logic states are decoded, the resolution obtained is 4 times (4X) the resolution of the codewheel. Thus a codewheel with 500 window and bar pairs can be decoded into 2000 quadrature states. See Figure 1 for more details.

**Question 7. What is an index pulse?**

Answer. An index pulse occurs on a third channel called channel I. A pulse occurs on this channel once for each full revolution of the

codewheel. Essentially, this pulse marks a singular position of the codewheel. This is an absolute reference added to an incremental encoder.

**Question 8. Of Cycle, Pulse Width, and State Width, which is the most consistent?**

Answer. Cycle is the most consistent. If you are trying to measure velocity by timing between edges, use the rising to rising (or falling to falling) on either channel A or B. Pulse width and state width are not as consistent.

**Question 9. What other terms are used within the industry to describe output waveforms?**

Answer. Other terms in the industry include: *Phase*: rising edge on A to rising edge on B. (This is equivalent to Avago's State 1 width. Avago

defines phase as the center of the high state on A to the center of the high state on B.)

*Flutter*: variation from cycle to adjacent cycle.

*Duty Jitter, Waterfall*: variation from pulse width to adjacent pulse width.

*Symmetry*: ratio between pulse high and pulse low (nominally unity).

*Edge to Edge Variation, Edge Separation, Phase Error*:

equivalent to State Width Error.

*Phase Jitter*: variation from rising edge on A to rising edge on B.

**Question 10. Do Avago encoders provide analog outputs (sinusoidal or quasi-sinusoidal signals)?**

Answer. No. Avago encoders provide only digital incremental output waveforms.

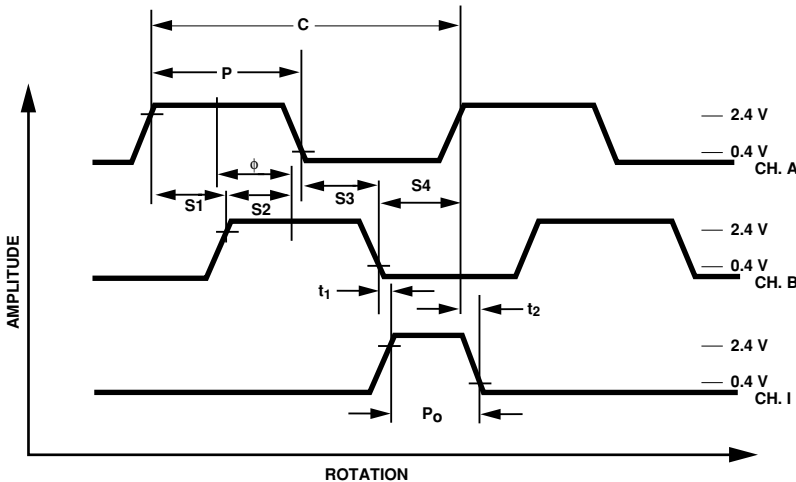

C = CYCLE (1 WINDOW AND BAR PAIR, 360°e)  
 S1 . . . S4 = LOGIC STATE WIDTH (4 STATES PER WINDOW AND BAR PAIR, EACH STATE IS 90°e)  
 P = PULSE WIDTH (RISING TO FALLING ON CH. A OR B, 180°e)  
 CH. I = INDEX CHANNEL (ONE PULSE PER FULL CODEWHEEL REVOLUTION)

Figure 1. Output Waveforms.

**Resolution**

**Question 11. How does Avago define resolution?**

Answer. Avago typically talks in terms of line density, which is the number of window and bar pairs per unit length. Line density is expressed either as lines per inch (LPin) or lines per mm (LPmm). For a rotary encoder, the line density is given by:

$$LPin (LPmm) = \frac{\text{Counts per Revolution}}{(2 \pi) (Rop)}$$

This gives the number of window and bar pairs per unit arc length at a given optical radius (Rop).

For linear encoder modules, the resolution is the number of window and bar pairs per unit of linear length.

Alternative to line density is the counts per revolution (CPR) with a specified optical radius (for rotary encoders).

**Question 12. What are the minimum and maximum resolutions available with Avago encoder modules?**

Answer. Avago can make encoder modules with resolutions from 30 LPin to 360 LPin (1.18 LPmm to 14.17 LPmm).

**Question 13. How can I get a rotary encoder resolution that is not one of the standard resolutions?**

Answer. Custom resolutions can be obtained by one of two ways. One way is to use a standard encoder module and design a custom codewheel. The line density of the module and the codewheel must match, but the optical radius can be varied to make a larger or smaller diameter codewheel which has a custom number of window and bar pairs.

Example: Customer wants 220 CPR encoder, which is between HEDS-9100 standard resolutions of 200 CPR and 256 CPR.

Steps:

- a.) Use HEDS-9100 #E00 (200 CPR at 11.00 mm Rop, LPmm = 2.89 lines/mm).
- b.) Match the LPmm of the module with the LPmm of

the new codewheel and solve for a new optical radius:

$$LPmm = \frac{CPR}{(2 \pi) (Rop)} \rightarrow Rop = \frac{CPR}{(2 \pi) (LPmm)}$$

$$Rop = \frac{220 \text{ CPR}}{(2 \pi) (2.89 \text{ lines/mm})} = 12.1 \text{ mm}$$

Thus the custom codewheel will be slightly larger than the standard codewheel to accommodate 20 extra window and bar pairs (Rop = 12.1 mm vs. Rop = 11.00 mm) but have the same line density. The modules are robust enough to handle the difference in optical radius.

The other way to get a custom resolution is to have Avago make a custom photodetector IC with the desired custom resolution. A custom codewheel is still required to work with the custom IC. Contact your local Avago sales representative for more information.

**Question 14. Will any codewheel work with any encoder module?**

Answer. No. The line densities of the module and codewheel must match. Thus a 200 LPin module will not work with a 120 LPin module.

**Question 15. How closely does the line density of the codewheel or codestrip have to match the line density of the module?**

Answer. For modules with less than 200 LPI resolution, a general rule of thumb is that the line densities must match within 5 lines/inch for the module to

function (0.2 lines/mm). For higher resolution, above 200 LPI up to 360 LPI, the mismatch must be 3% or less from the encoder resolution. Encoding performance degrades with mismatch and thus Avago cannot guarantee encoding specifications when significant mismatch occurs.

**Question 16. Can I use an encoder module to detect the presence or absence of an object?**

Answer. No. The module is looking for a certain light/dark pattern. The passing of an opaque or transparent material past the photodetector array may or may not cause a transition on either channel. The result is not predictable.

---

## Mounting

**Question 17. How are the encoder module mounting tolerances referenced?**

Answer. For the HEDS-9000, 9100, and 9200 series encoder modules, the tolerances are referenced from the centers of the aligning recesses. For HEDS-9700 series, the tolerances are referenced from the aligning post on the underside of the module.

**Question 18. Three channel encoders and modules require use of an alignment tool or other aligning aid. Do you need an alignment tool for two channel encoders and modules?**

Answer. With the exception of the HEDS-9000/9100 Extended Resolution Series, alignment aids are not required. However, using alignment aids will result in better performance and are recommended. The Extended Resolution modules, which are the HEDS-9000 Options T and U and the HEDS-9100 Options B and J, do require the use of alignment aids. In some cases, alignment aids can also improve assembly times.

**Question 19. Can adhesives be used instead of screws?**

Answer. Yes. A common adhesive used is RTV, made by GE or Dow Corning (GE 162, Dow Corning 3145) among others.

**Question 20. What is meant by "artwork side of codewheel"?**

Answer. The artwork side only refers to codewheels that are made of glass or mylar (plastic). On these codewheels, the "art" or window/bar pattern appears only on one side. Generally, it is better to have the artwork side closer to the photodetector array to cast a cleaner, sharper shadow. With metal codewheels, both sides are equivalent since the window is an absence of material. The artwork side does not apply here.

**Question 21. How will the gap between the codewheel and the detector side of the encoder module affect the output?**

Answer. In general, Avago encoders are not that sensitive to the codewheel gap. This is because

the lens collimates the LED light into a parallel beam and keeps the light/dark pattern fairly uniform. However, as the codewheel gets closer to the detector, the shadows cast by the codewheel get cleaner and sharper. This results in better light/dark contrast and subsequently somewhat better performance.

**Question 22. Does Avago provide mounting screws?**

Answer. No.

**Question 23. What is TIR?**

Answer. TIR stands for Total Indicated Runout and is the total movement that the codewheel window/bar pattern will have in a radial direction. Thus it is the total eccentricity of the codewheel. The factors which contribute to TIR are:

- Shaft eccentricity
- Shaft undersize relative to hub
- Off-center placement of hub relative to codewheel
- Shaft radial play due to bearing tolerance and uneven loading

TIR contributes directly to the cycle error and position error of the encoder.

**Question 24. Can Avago bend the leads of the encoder modules?**

Answer. Yes. The standard part numbers are: HEDS-9101, HEDS-9041, HEDS-9141, HEDS-9701, HEDS-9721, HEDS-9731, and HEDS-9781.

**Question 25. How do you remove an HEDS-5500 series encoder?**

Answer. The HEDS-5500 series encoders were not designed to be removed. However, it is possible to do so if done carefully. The procedure to remove one is essentially the assembly procedure in reverse. The steps are as follows:

- a.) Turn the encoder cap from the two-dot position to the one-dot position.
- b.) Insert hex wrench into side hole by the one-dot mark.
- c.) Push down on the hex wrench, and rotate the shaft slowly until you feel the setscrew. Insert wrench into hole and loosen setscrew. (This may take more than one attempt.)
- d.) *Carefully* unsnap the encoder housing from the encoder baseplate. Gently lift the encoder housing up off the shaft. If the housing is pulled off too quickly, the codewheel may be damaged.
- e.) Remove baseplate screws.

**Question 26. In the HEDS-5500 series assembly procedure, Step 4 calls for using the screwdriver slot to turn the encoder cap from the one-dot position to the two-dot position. If the encoder has an optional through-hole with no screwdriver slot, how do you turn from the one-dot to the two-dot position?**

Answer. Insert the hex wrench into one of the two side slots on the top of the encoder housing and rotate clockwise from the one-dot to the two-dot position.

---

## Materials

**Question 27. What is the material of the encoder module housing?**

Answer. For the HEDS-90xx/91xx/92xx, the material is Ryton R-4, a type of polyester with glass filling. For the HEDS-9700 series, the housing material is a type of polyester with glass filling named Valox.

**Question 28. What is the material of the HEDS-5500, HEDS-6500 and HEDR-542x series housing?**

Answer. All the housings of the above mentioned encoder series are made of Valox, polyester filled with glass.

**Question 29. What is the lens made of?**

Answer. The lens is polycarbonate. HEDR-8xxx lens is a type of epoxy based mold compound.

**Question 30. What are the codewheels made of?**

Answer. Codewheels are made either of nickel, nickel-plated copper, or stainless steel and glass. The hubs are made of aluminum. The codewheel setscrew is made of black anodized high-carbon steel.

---

## Reliability

**Question 31. Is there a reliability data sheet for Avago encoders?**

Answer. Yes, reliability data sheets are available for the HEDS-

9000, HEDS-9100, HEDS-9200, HEDS-5500, HEDS-6500, HEDR-542x and HEDR-8000 series.

**Question 32. Will Avago encoders work in a vacuum?**

Answer. Avago encoders are not characterized nor were they intended to work in a vacuum. Customers have tried with varying amounts of success.

**Question 33. Will Avago encoders work in a radioactive environment?**

Answer. Again, they were not characterized or intended for such conditions. Customers have tried this also, again with different amounts of success.

**Question 34. Will Avago encoders work in a fluid?**

Answer. No. Fluids ruin the optics, potentially cause electrical problems, and, depending on the fluid, may destroy the materials of the encoder.

**Question 35. How well do Avago encoders work in a dusty environment?**

Answer. Avago encoders are fairly robust to dusty environments. The encoders look at multiple sets of window and bar pairs. Thus a speck of dust at any one window will be averaged out by the other sets of windows and bars. Because of this averaging effect, a number of windows can be covered completely and the module will still not lose a count.

**Question 36. What solvents can be used to clean in the vicinity of the encoder modules?**

Answer. Avago has found that almost all solvents (besides water) will attack some part of the encoder module. This includes alcohols and freon-based cleaners. Avago has not qualified any solvent to be compatible with the encoder modules.

---

## Electrical

**Question 37. What kind of output drives do Avago encoders have?**

Answer. Avago encoders have a current source output of 125 microamps typical, 40 microamps minimum in the high state. The outputs can sink up to 3.2 mA under Recommended Operating Conditions (3.86 mA for three channel HEDS-9040/9140, HEDS-5540/5640).

**Question 38. I am trying to drive a fairly long length of cable. What kind of additional circuitry should I consider?**

Answer. For cable in the 6 to 10 foot range, pull-up resistors to +5 Volts on each output channel may suffice (3.3 K for two channel, 2.7 K for three channel). For longer lengths of cable, either a buffer or a line driver may be necessary.

**Question 39. I am having some problems with noise affecting my encoder signals. What should I do?**

Answer. There are several ways to improve noise immunity. Be careful to separate motor driver wires from encoder wires, and be sure to separate encoder channels from each other (i.e., do not twist CH A with CH B or CH I). Shielded twisted pair cable is recommended for encoder lines. Also, be sure to separate the ground lines of the motor/ amplifier and the encoder since high current switching in the motor can cause noise in the encoder output lines.

Pull-up resistors help somewhat with noise rejection. Additional circuitry, such as line drivers/ receivers and optocouplers, is much more effective in rejecting noise. In really noisy environments, additional circuitry may be the only way to totally eliminate a noise problem.

**Question 40. Does Avago provide line driver outputs?**

Answer. Yes. Avago has made available the HEDL-55xx/56xx encoders, which are HEDS-55xx/56xx encoders with a line driver board. This board uses an industry standard 26LS31 line driver IC. The line driver outputs are RS-422 compatible and provide complementary outputs on a 19 inch twisted pair ribbon cable. Both two and three channel encoders are available with the line driver option.

**Question 41. What is meant by "push-pull" circuitry?**

Answer. In determining the output for Channel A, the encoder photodetector is looking for signals for A and its complement A'. These signals are sent to a comparator such that when A receives more light than A', Ch. A is high. If A' receives more light than A, Ch. A is low. This arrangement is called "push-pull" circuitry.

The advantage is that the Ch. A output is insensitive to variation in the LED light level since A and A' are affected equally by the light source. Channels B and I are configured similarly.

**Question 42. Typically, how much current do the LED and photodetector IC draw?**

Answer. In the two channel modules and encoders, the LED typically draws about 15 mA and the IC draws about 2 mA. In the three channel modules and encoders, the LED draws about 45 mA and the IC draws about 10 to 12 mA.

---

## Miscellaneous

**Question 43. Does Avago provide codestrips?**

Answer. Avago does not sell codestrips, but a list of codestrip and codewheel vendors can be provided. Please contact Avago for further information.

**Question 44. How thick is an Avago codewheel?**

Answer. Codewheel thickness ranges from 0.054 mm (0.002 in.) to 0.55 mm (0.022 in.).

**Question 45. On the HEDS-9000/9100/9200 encoder modules, there are two metal straps on either side of the five pinouts. What are they for? Can they be cut or removed?**

Answer. These are the Ground and V<sub>CC</sub> lines which carry current to the LED light source. The pinouts, where the user connects Ground and V<sub>CC</sub>, are on the detector side of the module. The "straps" carry current to the emitter side of the module. If these lines are cut, the LED will not light up and the module will obviously not function.

**Question 46. Where is the index located on a 3-channel housed encoder?**

Answer. The index location is indicated on the HEDS-5500 data sheet. The index is located in the 6:00 position when the hex wrench is seated in the encoder set screw. The location is accurate within  $\pm 5$  degrees.

**Question 47: What torque should be applied to a codewheel setscrew?**

Answer. To ensure proper attachment of the codewheel to a shaft, proper torque must be applied. Torque applied once the setscrew has made contact with the shaft should be in the range 7 to 18 oz-in. This range is appropriate for most shafts. For harder shafts, applied torque may need to be in the high end of the stated range.

Exceeding the 18 oz-in maximum torque may strip the threads inside the hub. Applying less torque than 7 oz-in may result in movement of the setscrew in the customer's application. In both cases the hub will slip and the encoder will not function.

**Question 48: What is the necessary supply current for the HCTL-2000, HCTL-2016, and HCTL-2020?**

Answer. The current used by the HCTL-20xx is 1  $\mu$ A typical, 5  $\mu$ A maximum. This value is the Quiescent Supply Current,  $I_{dd}$ , on the data sheet. This data does not include current sourced in the output low condition, which is shown as a maximum of 4.8 mA on each of the 11 outputs (for the HCTL-2020). Therefore, the maximum necessary supply current can be calculated as:

$$5 \mu\text{A} + 11 \cdot 4.8 \text{ mA} = 52.8 \text{ mA}$$

However, if the interfacing electronics are implemented in CMOS with low input currents, one can see how the total current consumption can be reduced.

For example, with input current of 1  $\mu$ A, current consumed drops:

$$5 \mu\text{A} + 11 \cdot 1 \mu\text{A} = 16 \mu\text{A}$$

This data is only for the quiescent state and does not include current consumed when switching states. In most applications this is not a problem because the time spent switching is a small percentage of the total time.

**Question 49: What is the mating connector for the HEDR-54xx?**

Answer. The mating connector for the HEDR-54xx is made by Molex. (Part Number 51021-0500)

**Question 50: How far can an Encoder Line Driver transmit its signal?**

Answer. The line driver uses a 26LS31 driver to produce a complementary output. This chip produces signals in accordance with the RS-422-C standard. Transmission lengths vary based on frequency of the signal. The chip should be able to drive a signal across 4000 ft. of cable if the frequency of the signal is less than 100 kHz. If the frequency is around 10 MHz, the cable length decreases to 10 ft.

**Question 51: All About Connectors for the HEDS-5500/5600/5700.**

Answer. There are three connectors for the HEDx-55xx/56xx/57xx series of encoders. These connectors lock onto the back of any non-line driver or non-cabled version of these encoders. The part numbers are:

HEDS-8902: 4 wire leads for 2-channel parts

HEDS-8903: 5 wire leads for 3-channel parts

HEDS-8904: Empty connector for customer to build own cable

The HEDS-8904 is the locking part only. The customer needs to supply the housing for the pins (Berg Part Number 65039-032) and the contacts for each electrical connection (Berg Part Number 48045-000).

The HEDS-8904 housing fits around the 65039 housing and adds the ability to lock the connector into the back of the encoder.

Assembly instructions for HEDS-8904:

1. Crimp terminals onto wires.
2. Insert terminals into 65039 housing.
3. Insert 65039 housing into HEDS-8904 Housing.

**Question 52: What is the torque specification for the HRPG-AS16, HRPG-AS32, and HRPG-ASCA?**

Answer. The torque specification for the smooth versions of the HRPG series is 10 gmf-cm to 40 gmf-cm. This is not the specification for the detented versions.

**Question 53: What is the effect of IR Soldering on Avago Encoders?**

Answer. The HEDR-8000 and HEDR-8100 series encoders are designed for IR reflow soldering.

The HEDS-90xx, HEDS-91xx, HEDS-92xx, and HEDS-97xx encoders are not compatible with IR soldering. These encoders have a PVC lens that will melt at the temperatures involved with IR Reflow soldering. The lens will deform and damage the optics of the device. Failure may not be imminent, but performance over life will be greatly reduced as will robustness to dirt and mounting errors.

For product information and a complete list of distributors, please go to our web site: [www.avagotech.com](http://www.avagotech.com)

Avago, Avago Technologies, and the A logo are trademarks of Avago Technologies, Limited in the United States and other countries.  
Data subject to change. Copyright © 2007 Avago Technologies, Limited. All rights reserved.  
5988-5062EN - May 7, 2007

